

SEED METER OPERATION

GENERAL PLANTING RATE INFORMATION (Mechanical Seed Metering)

The size and shape of seed may affect the planting rate.

Finger Pickup Corn Meter

Larger grades will generally plant more accurately at the high end of the ground speed range than smaller grades. Higher than optimum speeds may result in population rate increase or higher incidence of doubles, particularly with small seed. Medium round corn seed is most desirable for planting accuracy at optimum speed.

Finger Pickup Oil Sunflower Meter

Larger grades will generally plant more accurately at the high end of the ground speed range than smaller grades. Higher than optimum speeds may result in population rate increase or higher incidence of doubles, particularly with small seed. No. 3 and/or No. 4 size oil sunflower seeds are recommended for use in the finger pickup seed meter equipped with oil sunflower fingers. No. 1 and/or No. 2 size confectionery sunflower seeds are recommended for use in the finger pickup seed meter equipped with corn fingers.

NOTE: Seed additives, added to the seed in the hopper, may adversely affect performance of the finger pickup seed meter and accelerate wear. See “Finger Pickup Seed Meter” in the Row Unit Operation section.

Brush-Type Seed Meter (Soybean, Milo/Grain Sorghum, Acid-Delinted Cotton)

Rate charts are given in seeds per acre as well as seed spacing in inches rounded to the nearest tenth of an inch. Because of the large range in seed size, pounds per acre is not a suggested method of selecting transmission settings. When using smaller size seeds it may appear the pounds per acre is below what was expected and vice versa on large seed. To determine pounds per acre, use the formula given in “Determining Pounds Per Acre (Brush-Type Seed Meter)” in the “Checking Seed Population” section of this manual.

NOTE: Due to a multitude of variables, seed spacing can be adversely affected at speeds above 5.5 MPH.

SEED METER OPERATION

FINGER PICKUP SEED METER

Refer to the planting rate chart for recommended seed drive transmission sprocket combinations.

D12220401

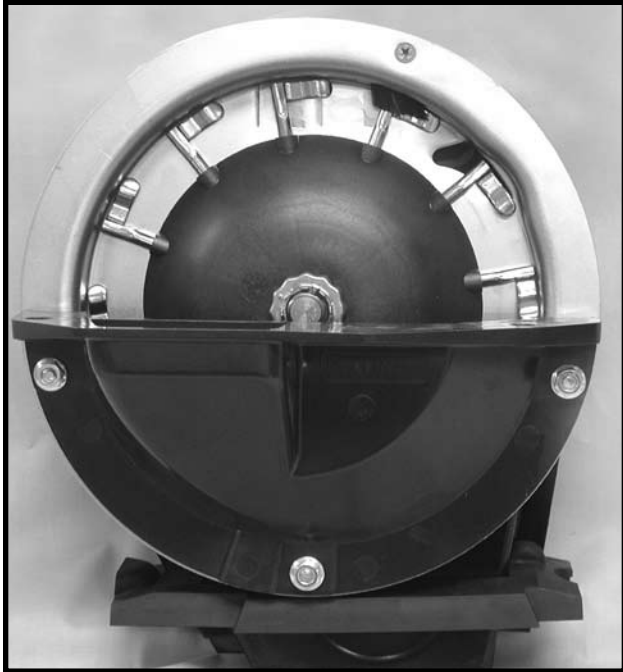

Shown With Corn Fingers Installed

The following seed fingers are available for use with the finger pickup seed meter:

(PLTR91/PLTR92/PLTR91a)

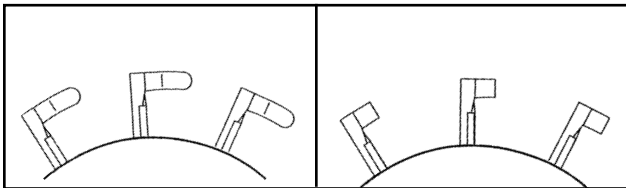

Corn Fingers

Oil Sunflower Fingers

No. 3 and/or No. 4 size oil sunflower seeds are recommended for use in the finger pickup seed meter equipped with oil sunflower fingers.

No. 1 and/or No. 2 size confectionery sunflower seeds are recommended for use in the finger pickup seed meter equipped with corn fingers.

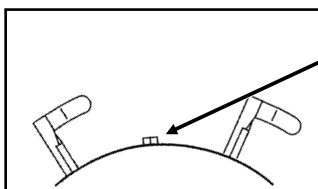

Half Rate Blank Finger

Blank fingers are used to replace alternate fingers in the finger wheel to reduce the planting rate by half while allowing the finger wheel to maintain a minimum of 40 RPM when planting low rates.

NOTE: Always check seed population in the field to ensure planting rates are correct.

NOTE: Powdered graphite is recommended for finger pickup seed meter lubrication to ensure efficient operation of the mechanism and to extend the life of its components. Mix one teaspoon of powdered graphite with the seed twice daily. Apply graphite on top of seed around the outer perimeter of the hopper as shown below. Graphite application frequency and volume may need to be increased if using additional seed treatments.

NOTE: Do NOT apply graphite only in the center of the hopper. It will filter too quickly through the seed and not distribute as evenly as desired.

D05230121b



NOTE: Follow manufacturer's recommendations when applying and mixing other seed treatments. If the additive is to be applied on top of the seed, apply around the outer perimeter of the hopper as with graphite.

See "General Planting Rate Information", "Finger Pickup Seed Meter Troubleshooting" and "Finger Pickup Seed Meter Inspection/Adjustment" for additional information.

CLEANOUT

To maintain genetic purity, thorough seed meter cleanout is important.

To clean the seed meter, disengage the seed drive and remove the seed hopper and meter. Dump the seed from the right rear corner of the hopper into a container. Turn the seed drive several times. Invert hopper to dump seed again. Shake the hopper and listen for any remaining seed. Turn seed drive and shake and dump hopper until all seed is removed.

SEED METER OPERATION

BRUSH-TYPE SEED METER

D12220403

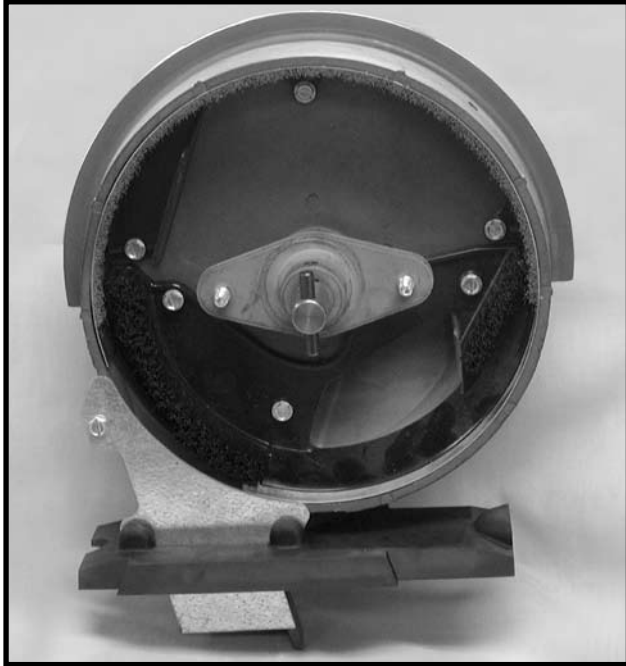

Shown Without Seed Disc Installed

60607-40a(PLTR13)

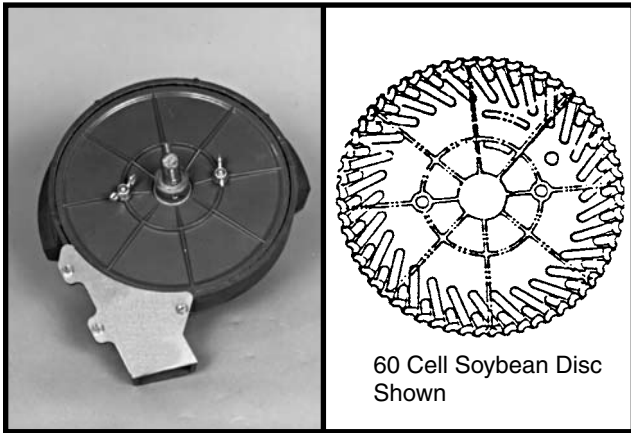

60 Cell Soybean Disc Shown

The following seed discs are available for use with the brush-type seed meter:

Soybean: 60 cells to meter seed sizes from 2200 to 4000 seeds per pound (Black color-coded).

(PLTR14)

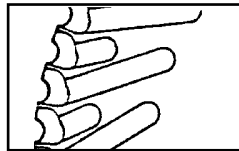

Specialty soybean: 48 cells to meter seed sizes from 1400 to 2200 seeds per pound (Dark blue color-coded).

(PLTR15)

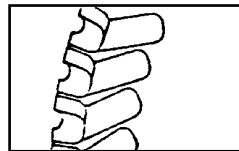

Small milo/grain sorghum: 30 cells to meter seed sizes from 14,000 to 20,000 seeds per pound (Red color-coded).

(PLTR16)

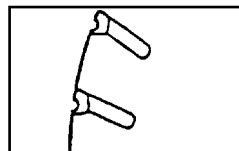

Large milo/grain sorghum:

30 cells to meter seed sizes from 10,000 to 16,000 seeds per pound (Light blue color-coded).

(PLTR17)

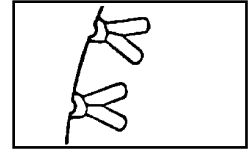

High-rate small milo/grain sorghum:

60 cells to meter seed sizes from 12,000 to 18,000 seeds per pound (Red color-coded). (PLTR18)

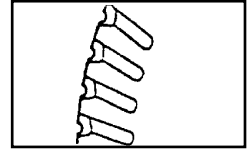

High-rate large milo/grain sorghum:

60 cells to meter seed sizes from 10,000 to 14,000 seeds per pound (Yellow color-coded). (PLTR19)

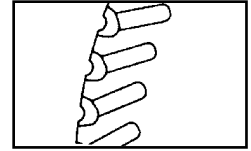

Cotton, acid-delinted: 30 cells to meter seed sizes from 4200 to 5200 seeds per pound (White color-coded).

(PLTR20)

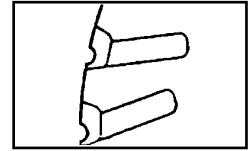

Large cotton, acid-delinted:

36 cells to meter seed sizes from 3800 to 4400 seeds per pound (Tan color-coded).

(PLTR21)

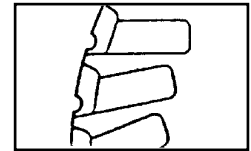

High-rate cotton, acid-delinted:

48 cells to meter seed sizes from 4200 to 5200 seeds per pound (Light green color-coded).

(PLTR22)

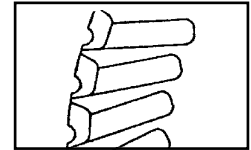

Hill-drop cotton, acid-delinted:

12 cells, 3 to 6 seeds/cell, to meter seed sizes from 4000 to 5200 seeds per pound (Brown color-coded). (PLTR23)

(PLTR23)

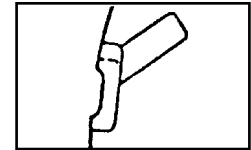

Small hill-drop cotton, acid-delinted:

12 cells, 3 to 6 seeds/cell, to meter seed sizes from 5000 to 6200 seeds per pound (Dark green color-coded).

(PLTR23)

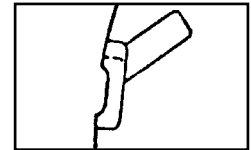

(RU14c)

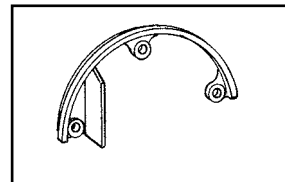

Use GD11122 upper brush retainer when using soybean and cotton discs.

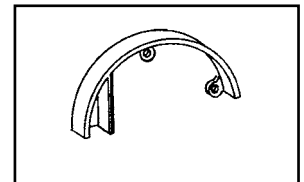

Use GD8237 upper brush retainer when using milo/grain sorghum discs.

SEED METER OPERATION

When installing the seed disc onto the meter hub, turn the disc counterclockwise while tightening the two wing nuts that retain the disc. The seed disc should have only slight resistance when rotated counterclockwise after wing nuts are tight.

The brush-type seed meter attaches to the seed hopper in the same manner as the finger pickup seed meter. Secure to bottom of seed hopper with two $\frac{5}{16}$ " thumbscrews. Tighten thumbscrews slightly with pliers. **DO NOT OVER TIGHTEN.**

Erratic seed spacing may result from misalignment between the drive coupler and seed meter input shaft. Misalignment may cause momentary stoppage of seed disc. Check alignment after initial installation. If adjustment is required, refer to "Meter Drive Adjustment" for correct procedure.

Refer to the planting rate charts in this manual for recommended seed drive transmission sprocket combinations.

One tablespoon of **powdered graphite** should be mixed with the seed each time the hoppers are filled. Regular graphite use will prolong the life of the brush-type seed meter components, improve seed spacing, and may reduce buildup of seed treatments. Apply graphite around the outer perimeter of the hopper as shown below.

D05300104b



NOTE: Do NOT apply graphite only in the center of the hopper. It will filter too quickly through the seed and not distribute as evenly as desired.

NOTE: Additional graphite or talc may be required to retard buildup of seed treatments on meter components. Frequency of monitor seed tube cleaning may be affected due to use of additional graphite or talc.

Talc seed lubricant may be used in lieu of or in addition to graphite to reduce seed treatment buildup on seed disc and meter components. Coat seed disc and brushes with talc before installing meter. Fill hopper $\frac{1}{2}$ full of seed, add $\frac{1}{4}$ cup of talc and **mix thoroughly**. Finish filling hopper, add another $\frac{1}{4}$ cup of talc and **mix thoroughly**. Adjust rate of talc use as needed so all seeds are coated, while avoiding a buildup of talc in the bottom of the hopper. Humid conditions and/or small sized seeds with extra seed treatment may require as much as one cup of talc per hopper to prevent seed treatment buildup on seed disc and/or brushes.

NOTE: Some liquid seed treatments or inoculants may create buildup on the seed disc or brushes. Check frequently for proper population and/or seed delivery when using any liquid seed treatment. All seed treatment should be thoroughly mixed with the seed per the manufacturers' recommendations. Seed treatment dumped on top of the seed after the hopper is filled, and not mixed properly may cause bridging of the seed in the meter, reducing population or stopping the meter from planting.

NOTE: Foreign material, such as hulls, stems, etc., may affect seed delivery. Clean seed is required to ensure accurate seed metering from the brush-type seed meter. Seed discs should be removed daily to check for buildup of foreign material, such as hulls, in the seed meter or the brushes.

CLEANOUT

To maintain genetic purity, thorough seed meter cleanout is important.

To clean the seed meter, disengage the seed drive and remove the seed hopper and meter. Dump the seed from the right rear corner of the hopper into a container. Disassemble seed disc by removing wing nuts. Empty the meter. Thoroughly inspect brushes in meter to ensure all seed is removed. Replace seed disc and install wing nuts.

SEED METER OPERATION

GENERAL PLANTING RATE INFORMATION (EdgeVac Seed Metering)

The size and shape of seed may affect the planting rate.

The following seed discs are available for use with the KINZE® EdgeVac® Seed Metering System:

Corn/Popcorn: 39 cell. Light blue color-coded. For all seed corn grades from 35 to 70 pounds per 80,000 kernel count unit or popcorn seed size range from 2210 to 4200 seeds per pound. Also used for No. 1 sunflower seeds. *When planting popcorn this seed disc requires use of seed baffle. See "Seed Meter" on pages 7-2 and 7-3 for additional information.*

Low-Rate Corn/Popcorn: 24 cell. Light green color-coded. For all seed corn grades from 35 to 70 pounds per 80,000 kernel count unit or popcorn seed size range from 2210 to 4200 seeds per pound. Also used for No. 1 sunflower seeds. *When planting popcorn this seed disc requires use of seed baffle. See "Seed Meter" on pages 7-2 and 7-3 for additional information.*

Soybean: 60 cell. Black color-coded. Seed size range from 2200 to 4000 seeds per pound. *This seed disc requires use of seed baffle. See "Seed Meter" on pages 7-2 and 7-3 for additional information.*

Soybean, High-Rate: 120 cell. Dark blue color-coded. Seed size range from 2200 to 4000 seeds per pound. *This seed disc requires use of seed baffle. See "Seed Meter" on pages 7-2 and 7-3 for additional information.*

Milo/Grain Sorghum: 60 cell. Yellow color-coded. Seed size range from 10,000 to 20,000 seeds per pound. *This seed disc requires use of seed baffle and cleanout brush. See "Seed Meter" on pages 7-2 and 7-3 for additional information.*

Hill-Drop Cotton, Acid-Delinted (3 Seeds Per Cell): 20 cell. Brown color-coded. Cotton seed size range from 3800 to 4400 seeds per pound. *This seed disc requires use of cleanout brush w/ball-type ejector. See "Seed Meter" on pages 7-2 and 7-3 for additional information.*

Small Hill-Drop Cotton, Acid-Delinted (3 Seeds Per Cell): 20 cell. Grey color-coded. Cotton seed size range from 4200 to 5200 seeds per pound. *This seed disc requires use of cleanout brush w/ball-type ejector. See "Seed Meter" on pages 7-2 and 7-3 for additional information.*

Cotton, Acid-Delinted/Small Dry Edible Bean: 54 cell. Dark green color-coded. Cotton seed size range from 3800 to 4400 seeds per pound or dry edible bean seed size range from 1200 to 2500 seeds per pound. *This seed disc requires use of cleanout brush w/ball-type ejector. See "Seed Meter" on pages 7-2 and 7-3 for additional information.*

Small Cotton/Sunflower: 54 cell. White color-coded. Cotton seed size range from 4200 to 5200 seeds per pound or sunflower seed sizes No. 2, 3 and 4. *This seed disc requires use of cleanout brush w/ball-type ejector. See "Seed Meter" on pages 7-2 and 7-3 for additional information.*

Large Dry Edible Bean: 54 cell. Tan color-coded. Seed size range from 800 to 1200 seeds per pound.

NOTE: Due to a multitude of variables, seed spacing can be adversely affected at speeds above 5.5 MPH.

NOTE: See "Seed Meter Singulator Brush And Vacuum Level Adjustments" on page 7-24.

SEED METER OPERATION

SEED METER

(METR71/METR71a)

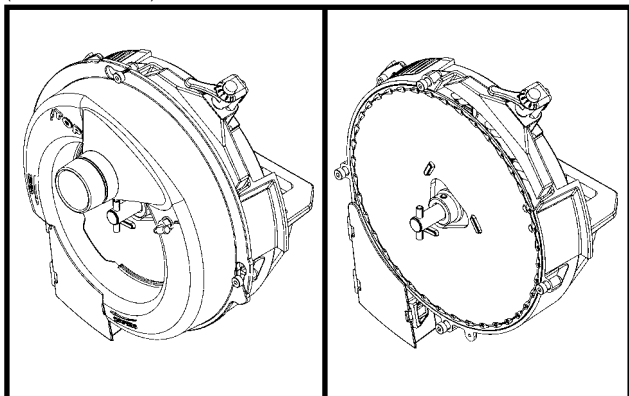

(METR70/D14467a)

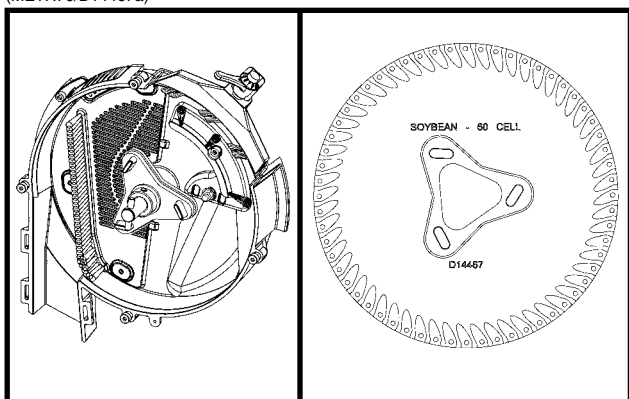

The seed discs below and at right are available for use with the KINZE® EdgeVac® Seed Metering System:

Corn/Popcorn: 39 cell. For all seed corn grades from 35 to 70 pounds per 80,000 kernel count unit. Popcorn seed size range from 2210 to 4200 seeds per pound. Also used for No. 1 sunflower seeds. *(Light blue color-coded.)* (D14465)

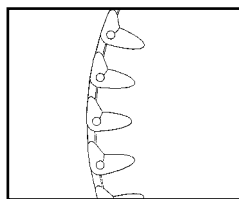

Low-Rate Corn/Popcorn: 24 cell. For all seed corn grades from 35 to 70 pounds per 80,000 kernel count unit. Popcorn seed size range from 2210 to 4200 seeds per pound. Also used for No. 1 sunflower seeds. *(Light green color-coded.)* (D16734a)

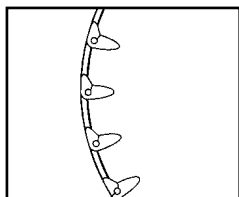

Soybean: 60 cell. Seed size range from 2200 to 4000 seeds per pound. *(Black color-coded.)*

(D14467a)

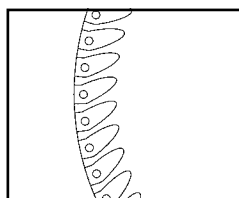

Soybean, High-Rate: 120 cell. Seed size range from 2200 to 4000 seeds per pound. *(Dark blue color-coded.)* (D14468a)

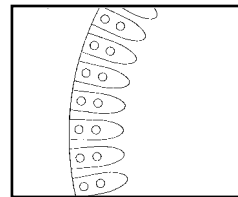

Milo/Grain Sorghum: 60 cell. Seed size range from 10,000 to 20,000 seeds per pound. *(Yellow color-coded.)* (D17050)

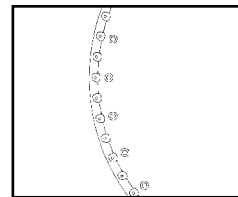

Hill-Drop Cotton, Acid-Delinted (3 Seeds Per Cell): 20 cell. Cotton seed size range from 3800 to 4400 seeds per pound. *(Brown color-coded.)* (D17187)

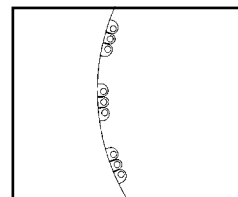

Small Hill-Drop Cotton, Acid-Delinted (3 Seeds Per Cell): 20 cell. Cotton seed size range from 4200 to 5200 seeds per pound. *(Grey color-coded.)* (D17187)

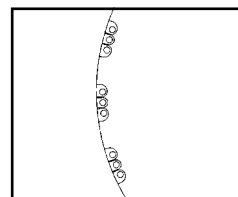

Cotton, Acid-Delinted/Small Dry Edible Bean: 54 cell. Cotton seed size range from 3800 to 4400 seeds per pound. Dry edible bean seed size range from 1200 to 2500 seeds per pound. *(Dark green color-coded.)* (D17186)

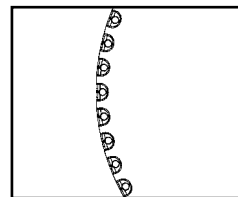

Small Cotton/Sunflower: 54 cell. Cotton seed size range from 4200 to 5200 seeds per pound. Sunflower seed sizes No. 2, 3 and 4. *(White color-coded.)* (D17186)

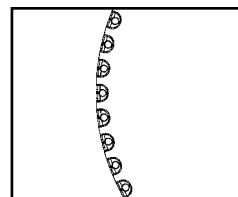

Large Dry Edible Bean: 54 cell. Seed size range from 800 to 1200 seeds per pound. *(Tan color-coded.)* (D14477)

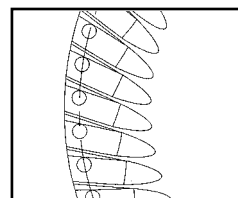

Install the selected seed disc. Position the vacuum cover on the meter by aligning the keyhole slots over the bolt heads. Push the cover on the meter and turn counter clockwise to lock in place. **See following page for additional components required with specific seed discs.**

SEED METER OPERATION

NOTE: Use of damaged seed or seed containing foreign material will cause plugging of seed disc orifices and require more frequent seed meter cleanout to prevent underplanting.

SEED BAFFLE

- Milo/Grain Sorghum
- Soybeans
- Popcorn

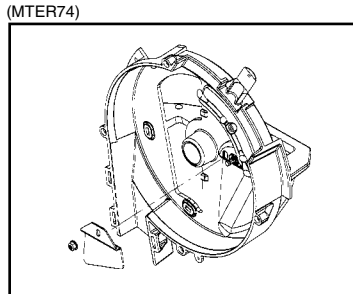

The **seed baffle** is designed to prevent excessive seed in the meter from restricting air flow through the seed. **Used with 60 Cell Milo/Grain Sorghum Disc, 60 Cell Soybean Disc, 120 Cell High-Rate Soybean Disc and 39 Cell and 24 Cell Popcorn Discs.**

CLEANOUT BRUSH

- Milo/Grain Sorghum

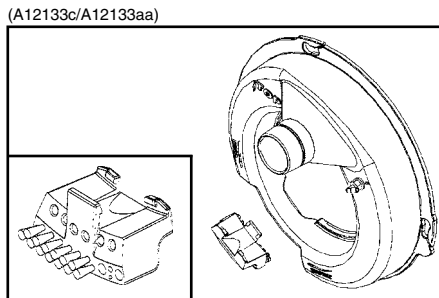

The **cleanout brush** is designed to remove foreign material and seed remnants to help prevent plugging of seed disc orifices.

Used with 60 Cell Milo/Grain Sorghum Disc.

CLEANOUT BRUSH W/BALL-TYPE EJECTOR

- Cotton
- Small Edible Beans

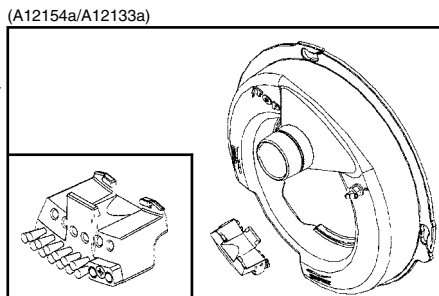

The **cleanout brush w/ball-type ejector** is designed to eject seed remnants from the seed disc orifices. **Used with 20 Cell Hill-Drop Cotton, Acid-Delinted (3 Seeds Per Cell) Discs and 54 Cell Acid-Delinted Cotton/Small Dry Edible Bean; and Small Cotton/Sunflower Discs**

(MTER70)

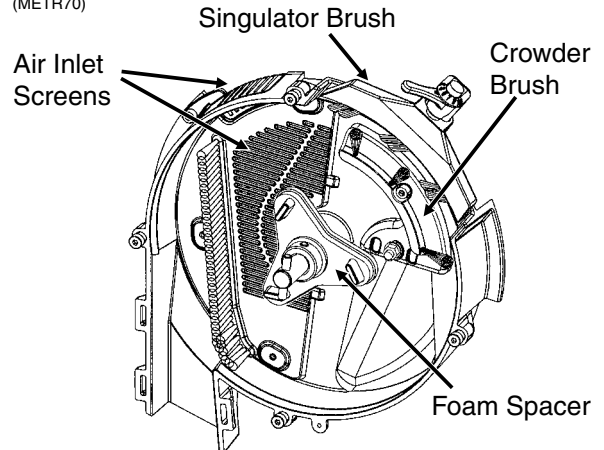

The crowder brush aids in the singulation of small flat seeds by (a) crowding seeds to the outer perimeter of the seed disc and (b) orienting seeds to allow the singulator brush to be more effective.

The air inlet screens allow air to enter the system and aids in keeping field residue or other foreign material out of the meter.

The foam spacer gently preloads the seed disc against the vacuum cover when no vacuum is present.

(MTER71)

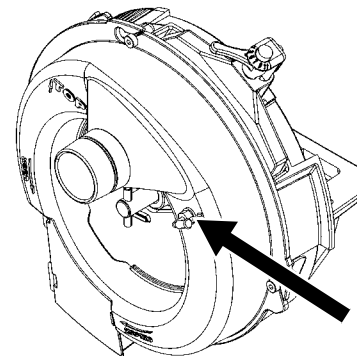

The $\frac{3}{16}$ " hose barb elbow on the seed meter vacuum cover allows measurement of vacuum level at each meter. A customer-supplied vacuum gauge is required.

See "Seed Meter Singulator Brush And Vacuum Level Adjustments", "Seed Meter Maintenance" and "Preparation For Storage" for additional EdgeVac® Seed Metering System information.

SEED METER OPERATION

LUBRICATION - CONVENTIONAL HOPPERS

One tablespoon of **powdered graphite** should be mixed with the seed each time the hoppers are filled. Regular graphite use will prolong the life of the vacuum seed meter components, improve seed spacing, and may reduce buildup of seed treatments. Apply graphite around the outer perimeter of the hopper as shown below.

D05300104b



NOTE: DO NOT apply graphite only in the center of the hopper. It will filter too quickly through the seed and not distribute as evenly as desired.

NOTE: Additional graphite or talc may be required to retard buildup of seed treatments on meter components. More frequent cleaning of monitor seed tubes may be necessary due to use of additional graphite or talc.

Talc seed lubricant may be used in lieu of or in addition to graphite to improve seed release from the meter. Fill hopper $\frac{1}{2}$ full of seed, add $\frac{1}{4}$ cup of talc and **mix thoroughly**. Finish filling hopper, add another $\frac{1}{4}$ cup of talc and **mix thoroughly**. (For sunflowers, increase talc amount from $\frac{1}{4}$ cup to $\frac{1}{2}$ cup.) Adjust rate of talc use as needed so all seeds are coated, while avoiding a buildup of talc in the bottom of the hopper. Humid conditions and/or small sized seeds with extra seed treatment may require as much as one cup of talc per hopper to maintain meter performance.

NOTE: Some liquid seed treatments or inoculants may create buildup on the seed disc or brushes. Check frequently for proper population and/or seed delivery when using any liquid seed treatment. All seed treatment should be thoroughly mixed with the seed per the manufacturers' recommendations. Seed treatment dumped on top of the seed after the hopper is filled, and not mixed properly may cause bridging of the seed in the meter, reducing population or stopping the meter from planting.

LUBRICATION - ASD HOPPERS

IMPORTANT: Use powdered graphite or talc with each fill of seed. Additional graphite or talc may be required to retard buildup of seed treatments on meter components. Frequency of monitor seed tube cleaning may be affected due to use of additional graphite or talc.

82354-1e



Powdered graphite should be added with the seed each time the bulk seed hopper is filled. Use $1 \frac{1}{2}$ cups per hopper fill for 16 row machines. Graphite should be added in layers as the bulk seed hoppers are filled. The use of powdered graphite will prolong the life of the seed meter components, reduce buildup of seed treatment on components in the meter and improve seed spacing.

Talc seed lubricant may be used in lieu of or in addition to graphite to reduce seed treatment buildup on bulk fill air delivery components, seed discs and other meter components and will improve meter performance. Coat seed discs and brushes with talc before installing meters. Fill each bulk hopper $\frac{1}{2}$ full of seed, add $4 \frac{1}{4}$ cups of talc and mix thoroughly. Finish filling bulk seed hopper, add another $4 \frac{1}{4}$ cups of talc. Adjust rate of talc use as needed so all seeds are coated, while avoiding a buildup of talc in the bottom of the hopper. Humid conditions and/or small sized seeds with extra seed treatment may require additional talc to prevent seed treatment buildup on seed discs and/or other meter components.

SEED METER OPERATION

SEED METER CLEANOUT

To maintain genetic purity, thorough seed meter cleanout is important.

To clean the seed meter, disengage the seed drive and remove the seed hopper and meter. Lay the hopper on its right side.

Disassemble seed meter by rotating vacuum cover clockwise to align key hole slots with bolt heads. Lift off cover. Remove seed disc. Empty the meter and hopper by allowing the seed to run out of the meter. Inspect brushes in meter to ensure all seed is removed. Replace seed disc and install vacuum cover.

NOTE: Use of damaged seed or seed containing foreign material will cause plugging of seed cell orifices and require more frequent seed meter cleanout to prevent underplanting.

SEED METER OPERATION

SEED METER SINGULATOR BRUSH AND VACUUM LEVEL ADJUSTMENTS

SEED DISC SELECTION

CROP	CELLS	SEED SIZE RANGE	COLOR-CODE
Corn	39	35 To 70 Lbs./80,000 Kernel Count Unit	Light Blue
Low-Rate Corn	24	35 To 70 Lbs./80,000 Kernel Count Unit	Light Green
Popcorn	39	2210 To 4200 Seeds/Lb.	Light Blue
Low-Rate Popcorn	24	2210 To 4200 Seeds/Lb.	Light Green
Soybean	60	2200 To 4000 Seeds/Lb.	Black
High-Rate Soybean	120	2200 To 4000 Seeds/Lb.	Dark Blue
Milo/Grain Sorghum	60	10,000 To 20,000 Seeds/Lb.	Yellow
Hill-Drop Cotton, Acid-Delinted (3 Seeds Per Cell)	20	3800 To 5200 Seeds/Lb.	Brown
Cotton, Acid-Delinted	54	3800 To 5200 Seeds/Lb.	Dark Green
Dry Edible Bean (Small)	54	1200 To 2500 Seeds/Lb.	Dark Green
Dry Edible Bean (Large)	54	800 To 1200 Seeds/Lb.	Tan
Small Cotton/Sunflower	54	4200 To 5200 Seeds/Lb.	White

EDGEVAC® INITIAL SETTINGS

CROP	SIZE	SEED DISC	SINGULATOR BRUSH SETTING	VACUUM SETTING (H ₂ O)	SEE NOTES
Corn	35-45 Lbs./80K	Corn/Popcorn	7	20	4, 5
	45-60 Lbs./80K	Corn/Popcorn	6	20	4, 5
	60-70 Lbs./80K	Corn/Popcorn	5	20	4, 5
Popcorn	2210-4200 Seeds/Lb.	Corn/Popcorn	9	18	1, 4, 5
Soybeans	2200-4000 Seeds/Lb.	Soybean	5	10	1
Milo/Grain Sorghum	10,000-20,000 Seeds/Lb.	Milo/Grain Sorghum	7	18	1, 2
Hill-Drop Cotton	3800-5200 Seeds/Lb.	Hill-Drop Cotton	8	23	3
Cotton	3800-5200 Seeds/Lb.	Cotton	8	20	3
Edible Beans	800-1200 Seeds/Lb.	Large Edible Bean	5	18	5
	1200-2500 Seeds/Lb.	Small Edible Bean	6	18	3, 5
Small Cotton/Sunflower	4200-5200 Seeds/Lb.	Small Cotton/Sunflower	5	20	3

NOTES:

1. Requires use of seed meter baffle. Refer to page 7-3 for additional information.
2. Requires use of cleanout brush. Refer to page 7-3 for additional information.
3. Requires use of cleanout brush w/ball-type ejector. Refer to page 7-3 for additional information.
4. For flat seeds, higher vacuum level may be required.
5. Larger seeds may require a lower numbered singulator brush setting from the initial setting. Smaller seeds may require a higher numbered setting.

Refer to the planting rate charts in this manual for seed drive transmission sprocket combinations.

IMPORTANT: See “General Planting Rate Information” and “Checking Seed Population” pages for additional information. Always check seed population in the field to ensure planting rates are correct.

NOTE: Singulator brush settings are marked from 1 thru 11. The lower the singulator brush setting, the less aggressive. The higher singulator brush settings are the most aggressive. Refer to illustrations on page 7-24.

NOTE: Optimum meter performance will be attained with consistent seed size and shape. A mixture of seed sizes and shapes will affect meter performance.

NOTE: Use 1 tablespoon powdered graphite with each hopper fill of seed. Seed treatment, foreign material, dirt or seed chaff may cause gradual reduction of seed disc fill (population). See “Seed Meter”.

NOTE: Excessive seed treatment, humidity and light-weight seed can affect meter performance. Use ½ cup of talc with each hopper fill of seed and mix thoroughly so that all seeds are coated, adjust rates as needed. Use of talc will aid the seed flow into the meter, singulation and seed drop from the disc.

SEED METER OPERATION

STEP 1 Select seed disc (and seed meter baffle, cleanout brush and/or cleanout brush w/ball-type ejector if applicable) to match crop and population.

STEP 2 Adjust the singulator brush to initial setting. Note that seed size, seed shape, seed treatments, travel speed and planting rate will all affect meter performance.

D06260660

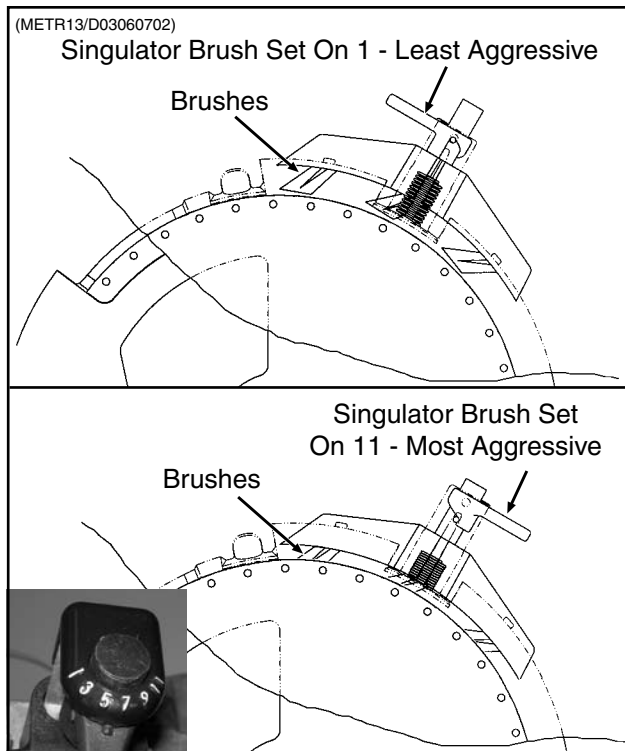
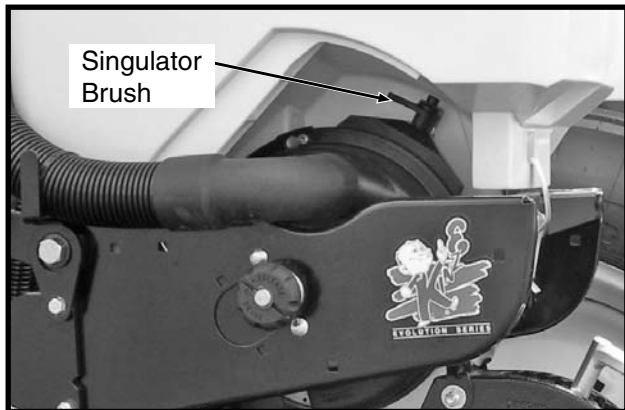

STEP 3 With vacuum fan running, lower planter to planting position and drive forward a short distance to load seed into the seed disc cells.

Adjust vacuum level to the initial setting according to the tables on preceding page. Note that seed size, seed shape, seed treatments, travel speed and planting rate will all affect meter performance.

NOTE: Vacuum reading will be much lower when seed disc cells are empty. Prior to setting vacuum level, load all seed cells.

See “Digital Vacuum Gauge Operation” in Machine Operation section

NOTE: Operate vacuum fan 3-5 minutes to bring oil up to normal operating temperature prior to making the final vacuum level adjustment.

STEP 4 Perform optional seed disc fill check.

D101906132



D101906130



With vacuum hose connected and vacuum fan operating, remove vacuum cover and seed disc as an assembly. Inspect seed discs for proper seed fill.

See “Seed Metering System Troubleshooting” at the end of this section.

SEED METER OPERATION

SEED METER MAINTENANCE

(METR71)

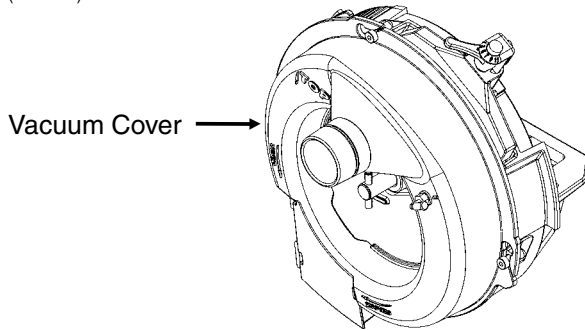

Clean, high quality seed should be used for maximum meter accuracy. Damaged or cracked seed, hulls or foreign material may become lodged in the seed disc orifices and greatly reduce meter accuracy.

It is suggested that the seed disc be inspected and cleaned daily, checking for any buildup of foreign material or any blocked orifices. Clean the seed disc by washing it with soap and water as needed. Dry thoroughly.

Inspect singulator brush for wear and replace if necessary following every 200 acres per row of operation.

The seed disc and/or vacuum cover should be replaced if abnormally high vacuum is required for consistent operation or if consistent operation can not be achieved. If adjustment of the singulator brush does not affect performance of the meter or if the brushes appear frayed, the singulator brush may need to be replaced. If the seed disc orifices are plugged frequently with seed remnants, the cleanout brush or cleanout brush with ball-type ejector (if applicable) may need to be replaced. High quality seed should be used to attain best performance.

(METR70)

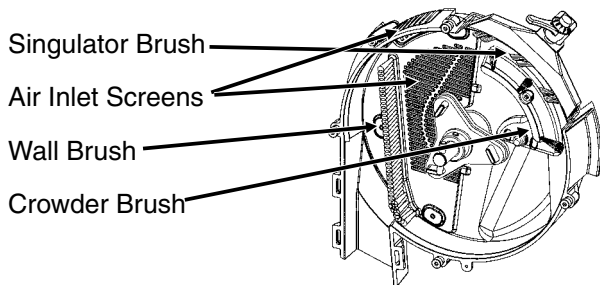

Prior to each planting season, inspect seed discs, singulator brush, crowder brush, wall brush and air inlet screens and clean or replace as needed.

See "Preparation For Storage" for additional EdgeVac® Seed Metering System maintenance.

IMPORTANT: Replace hopper lids after hoppers are filled to prevent accumulation of dust or dirt in the seed meter which will cause premature wear.

NOTE: Remove seed discs from meters for annual storage and store the seed discs vertically on a dowel or pipe.

VACUUM MANIFOLD MAINTENANCE

In the course of normal operation, dust will accumulate in manifolds and hoses. Manifolds should be cleaned annually. More frequent cleaning may be necessitated by abnormally dusty planting conditions.

Remove vacuum hose from each seed meter. Operate the vacuum fan at full hydraulic flow from the tractor for two minutes to clear manifolds, hoses and fittings of dust and debris.

SEED METER OPERATION

SEED METERING SYSTEM TROUBLESHOOTING

PROBLEM	POSSIBLE CAUSE	SOLUTION
Low seed count.	Meter RPM too high.	Reduce planting rate or planting speed.
	Singulator brush setting too aggressive.	Adjust singulator brush.
	Vacuum level too low.	Increase fan speed.
	Seed sensor not picking up all seeds dropped.	Clean seed tube. Move meter to different row.
	Seeds sticking to seed disc.	Use graphite or talc to aid release.
	Seed treatment buildup in seed disc recesses.	Reduce amount of treatment used and or mix thoroughly. Add talc.
	Seed size too large for disc used.	Use appropriate disc for seed size.
	Wrong seed disc.	Use appropriate disc for seed type and size.
	Failed/worn drive components.	Inspect and replace parts as required.
	Plugged orifices in seed disc.	Inspect and clean disc. Check cleanout brush. (If Applicable)
	Loss of vacuum at meter.	Check for foreign material between vacuum cover and disc. Inspect parts for wear/damage. Clean or replace as required.
	Seed bridging in hopper.	Add graphite to improve seed flow.
	Faulty vacuum gauge reading.	Repair/replace gauge.
	Dirt in vacuum manifold.	Check vacuum manifold for dirt and clean.
	Seed baffle (If Applicable) not allowing seed flow due to bridging of seed.	Thoroughly mix talc to coat all seeds. Remove seed baffle. See "Seed Meter" in Seed Meter Operation/Maintenance section.
	60 cell soybean disc not filling properly due to excessive RPM.	Replace with 120 cell soybean disc.
	Seed disc worn.	Replace.
Vacuum cover worn.	Replace.	
Not planting seed.	Seed hoppers empty.	Fill seed hopper.
	Seed tube plugged/damaged.	Clean or replace tube.
	Meter drive damaged.	Repair/replace drive components.
	Low/no vacuum.	Inspect vacuum system and repair as necessary.
	Singulator brush setting too aggressive.	Adjust singulator brush.
	Faulty vacuum gauge.	Repair/replace vacuum gauge.
	Seed bridging in hopper.	Add graphite to improve seed flow.
	Loss of vacuum at meter.	Check for foreign material between vacuum cover and disc. Inspect parts for wear/damage. Clean and/or replace as required.
	Wrong seed disc.	Use appropriate disc for seed type and size.
	Meter drive clutch not engaged.	Engage drive clutch.
	Fan not running.	Start fan.
	Dirt in vacuum manifold.	Check vacuum manifold for dirt and clean.

(Continued On Following Page)

SEED METER OPERATION

SEED METERING SYSTEM TROUBLESHOOTING (Continued)

PROBLEM	POSSIBLE CAUSE	SOLUTION
Not planting seed. (Continued)	Seed baffle (If Applicable) not allowing seed flow due to bridging of seed.	Thoroughly mix talc to coat all seeds. Remove seed baffle. See "Seed Meter" in Seed Meter Operation/Maintenance section.
	60 cell soybean disc not filling properly due to excessive RPM.	Replace with 120 cell soybean disc.
High seed count.	High vacuum.	Adjust vacuum level to appropriate level.
	Wrong seed disc.	Replace seed disc.
	Singulator brush setting not aggressive enough.	Adjust singulator brush.
	Worn singulator brush.	Inspect brush and replace as required.
	Seed leaking past wall brush.	Inspect wall brush condition and installation. Replace as necessary.
	Faulty vacuum gauge.	Check gauge line for dirt/obstruction. Repair/replace vacuum gauge.
Poor seed spacing.	Obstruction in seed tube.	Clean seed tube.
	Dirty/damaged seed disc.	Inspect seed disc for damage, foreign material in orifices or seed treatment buildup in recesses. Clean or replace as required.
	Wrong vacuum setting.	Adjust vacuum to appropriate level.
	Excess foreign material in seed.	Inspect and clean meter and seed discs. Use clean, undamaged seed.
	Incorrect singulator brush setting.	Adjust singulator brush to appropriate setting.
	Inconsistent driveline.	Inspect drive components for rust, misalignment, worn or damaged parts. Replace/repair as required.
	Toolbar not level or wrong height.	Adjust hitch to level toolbar and row units.
	Planting too fast for conditions.	Reduce speed.
	Rough field conditions.	Reduce speed.
Irregular seed population.	Driving too fast.	Reduce speed.
	Drive wheels slipping.	Reduce speed. Decrease row unit down pressure spring settings.
Unable to achieve desired vacuum level.	Tractor hydraulic flow set too low.	Increase flow to fan motor.
	Incorrect hydraulic connections.	Check all hydraulic connections and hose routings.
	Damaged fan components.	Inspect motor and impeller for wear/damage and repair/replace as necessary.
	Vacuum hose pinched/kinked/ blocked.	Inspect air lines for any damage or obstruction. Clean air lines and manifold by removing end cap from manifold and running fan at high speed.
	Vacuum hose loose/disconnected.	Inspect and reattach all air hoses.
	Tractor not producing required hydraulic flow/pressure.	Have tractor serviced by qualified technician.
	Dirt in vacuum gauge line. clean.	Check gauge line for dirt/obstruction and clean.